



Design Concepts

Eaton's Carter Model 60554 Hydrant Pit Valve is a family of valves that includes lanyard, air or dual air/lanyard operated pilot valves, with the latter available with a defueling option.

The latest Model 60554 Hydrant Pit Valves meet all the requirements of the 3rd edition of API/IP Bulletin 1584, including the new breakaway and strength requirements.

The basic hydrant pit valve consists of three basic parts, lower valve assembly, upper valve assembly (or API outlet adapter) and either the standard pilot valve or one of three patented pilot valve actuators (Model 64230, Model 64231 and Model 64280), available as Option X. The lower valve assembly contains an isolation valve which will allow the removal and servicing of the upper valve assembly and the pilot valve assembly while the pit valve is still installed. (See maintenance manual SM60554 for proper instructions). The upper portion of all versions of Model 60554 are now furnished with a replaceable part that contains the interface with the hydrant coupler. This minimizes replacement parts expense and allows for easy replacement of the outlet wearing surfaces.

An option is also available to bring the valve into compliance with IP standards by adding the appropriate 6-inch inlet flange adapter. The outlet conforms to the API Bulletin 1584 standard.

Model 60554 Hydrant Pit Valve is designed to minimize the propagation of surge pressure shocks into the upstream piping system during closure of the valve.

Features

- Standard aluminum two-piece upper half standard, replaceable API outlet adapter of stainless steel per API Bulletin 1584. Ductile iron and stainless uppers with replaceable outlet optional.
- Standard inlet flange mates with 4-inch 150 lb ANSI flange
- Optional inlet flange mates with 6-inch 300 lb ANSI flange, making valve conform to the IP standard
- Closing time is 2-5 seconds
- New pilotless valve (Option X) reduces maintenance costs, lanyard, air or dual air/lanyard operated pilot valve available (for small or large pit applications)
- Servicing valve, standard, provides means to remove the upper valve assembly and pilot valve assembly with the unit still installed
- Dual pilot adds true deadman backup to coupler, same as air-operated pilot. Hydrant valve is automatically closed at the end of the refueling operation. Lanyard operation can also be used with Option X valves.
- All seals are field replaceable
- Large pressure equalizing valve in the outlet is standard
- Defueling capability optional with any air or dual air/lanyard operated pilot
- Stone guard optional with 6-inch inlet flange option
- Ductile iron epoxy coated for corrosion protection
- Main piston well-guided to minimize piston seal wear
- 10- or 20-mesh screen options available

Model Descriptions

There are seven basic valves to which various modifications may be added by option letters as shown below. The six basic model numbers are as follows:

- Model 60554D — Lanyard operated pilot valve for manual on/off control. Valve allows flow in the fueling direction only.
- Model 60554E — Air-operated pilot valve for deadman control. Valve allows flow in the fueling direction only.
- Model 60554F — Dual air and lanyard operated pilot valve for deadman control and manual on/off control for use in small pits only (12 or 13-inch dia.). Uni-directional only, unless combined with Option J.
- Model 60554J — Air-operated pilot valve for deadman control with defuel control to allow flow of fuel in either fueling or defueling direction
- Model 60554U — Dual air and lanyard operated pilot valve for deadman control and manual on/off control for use in standard pits (18-inch or larger). Uni-directional only, unless combined with Option J.
- Model 60554-3D — Same as Model 60554D except material of outer housing is ductile iron per ASTM A395 (special order only). The upper and lower valve assemblies are fastened together with 15 metric threaded screws instead of the normal 8-UNF threaded screws (replaced Model 60554-2D). Two-piece upper half not available on this unit.

- Model 60554X — Valve with the major operating part of the pilot valve contained on a quick disconnect actuator assembly located on the hydrant service hose. Can be used as air/fuel pressure operation (with Model 64230 Actuator Assembly) or with lanyard backup (with Model 64231 Actuator Assembly). Actuator assemblies ordered separately. Includes ductile iron inlet housing, two-piece aluminum upper housing with replaceable stainless steel outlet, dust cap and high capacity pressure equalizing valve.

**Model 64231
Pilot Valve Actuator
with lanyard override**



**Model 64230
Pilot Valve Actuator**



**Model 64280
Pilot Valve Actuator**



U.S. Pat. No. 7,762,274

Technical Data

Installation Information

It is critical that the mating coupler (shown at right) be connected correctly and the pit lid be able to close completely. The hydrant valve's installation depth depends upon the brand of pit used. The thickness of the pit lid should be checked to be sure that it will clear the hydrant valve before setting the pit. The dimensions noted herein were correct for pits made in the United States at the time of printing. Eaton cannot be responsible for changes in the pits. The dimensions, shown are for reference only.

Dimensions are shown in inches (millimeters)

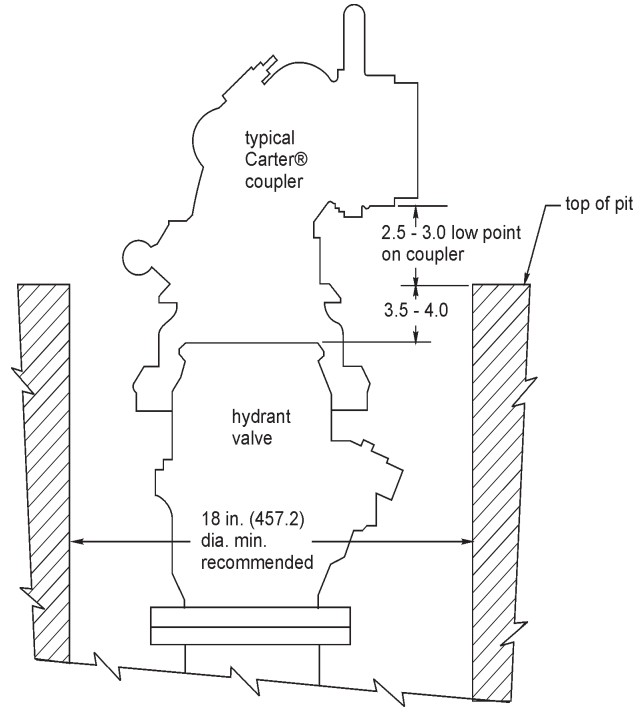

Technical Information

- Working Pressure — 300 psi (20.7 bar)
- Closing Time — 2 to 5 seconds
- Overshoot — 60.0 gals (225 liters) maximum at 1200 US gpm (4500 l/min.)
- Pilot valve air pressure required for Options E, F, J, U or X — 60 psi min. (4.2 bar)
- Mates Eaton's Carter Hydrant Coupler Models 60600, 60600-1, 60700-1, 64702, 64800, 64801, 64802, 64804, 64900, 64901, 64902, 61525 and all other API style couplers

Dimensional Specifications

The drawing (right) provides envelope dimensions for installation purposes only. They are not intended for inspection purposes.

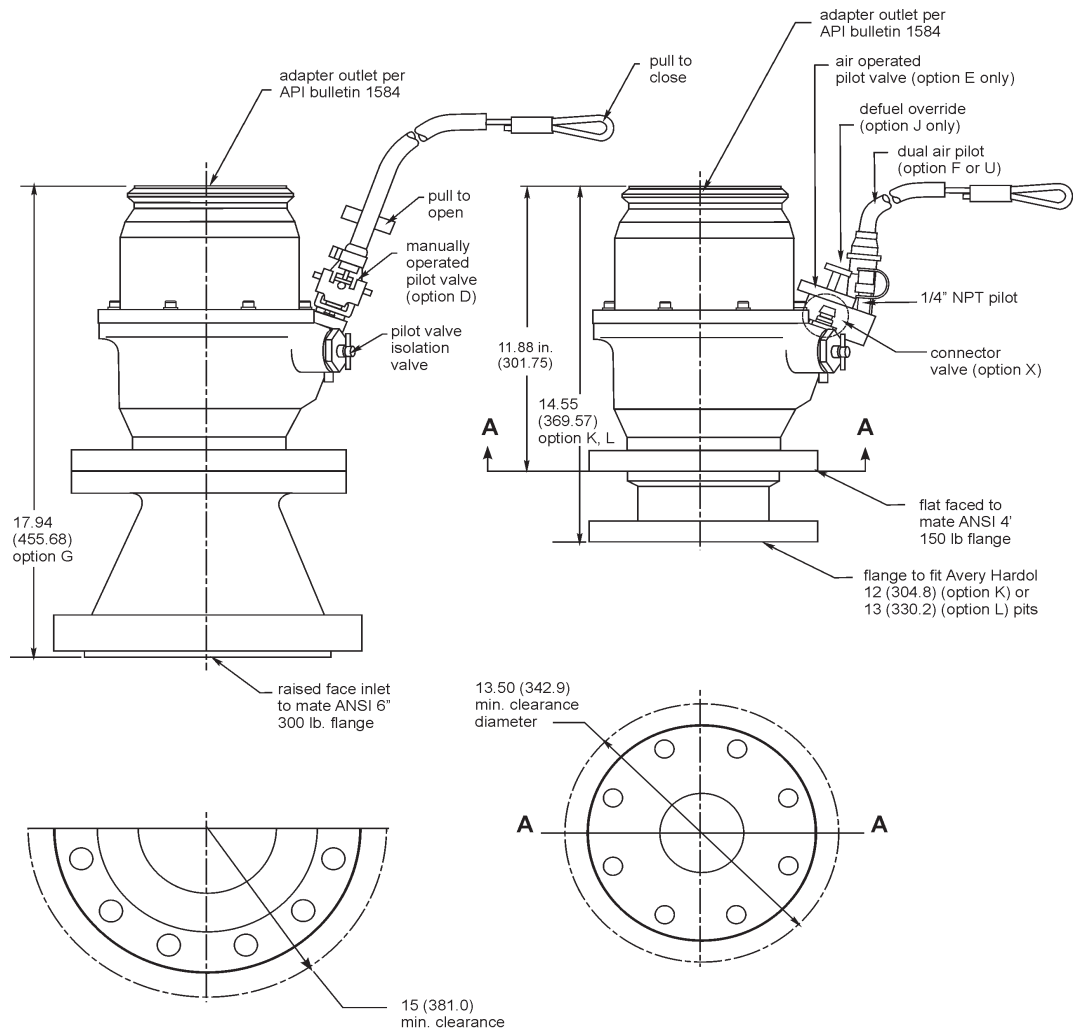

Illustrated Options

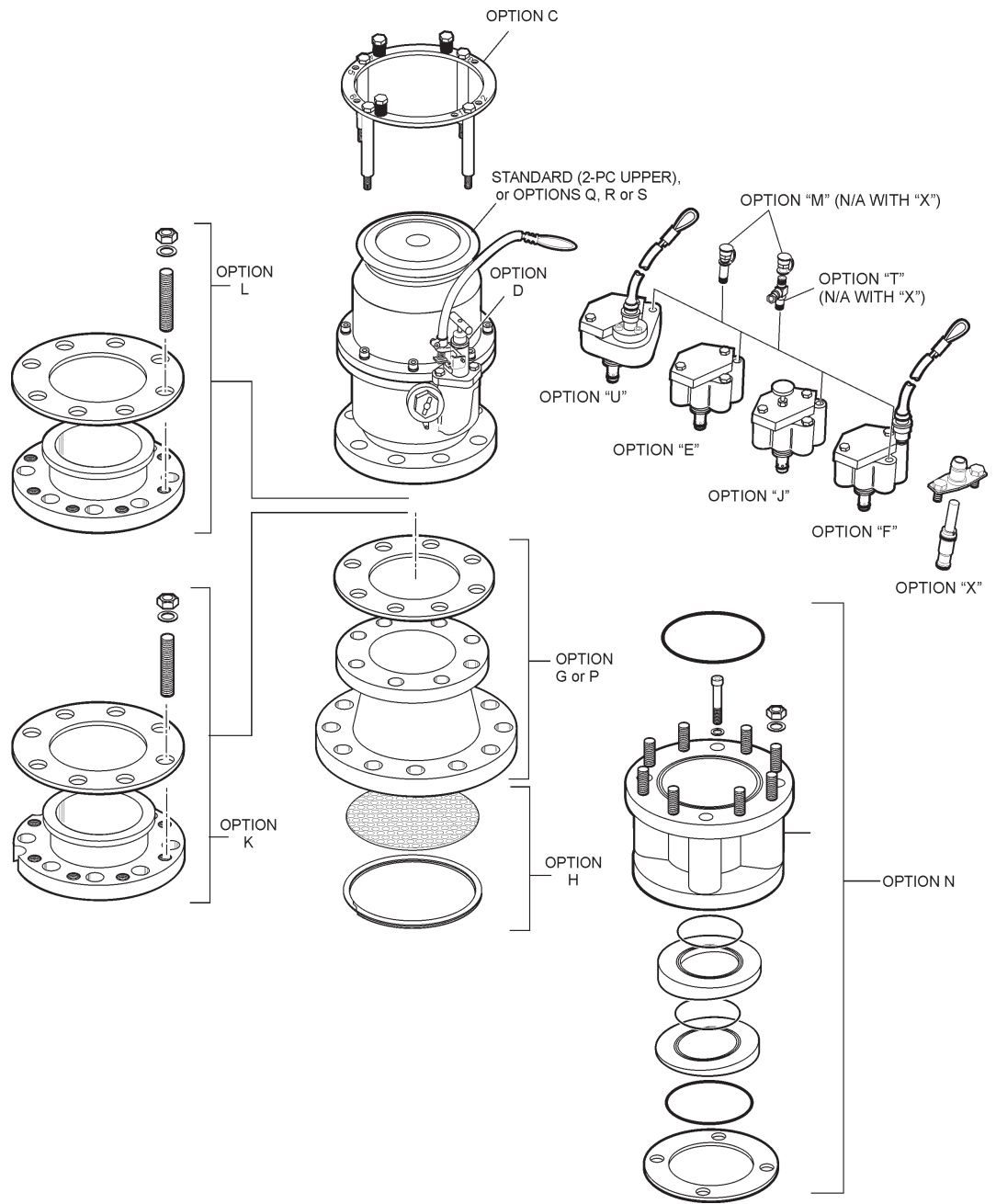

Ordering Data

Option letters may be combined with the basic units, except as noted, to customize the valve to fit specific installation requirements. Note basic models referenced on page 2, "Model Descriptions" section.

Option	Description	Option	Description
A	Adds 10-mesh screen between upper and lower halves of the unit (81557-10)	N	Adds adapter kit for installing unit into 12 or 13-inch Avery Hardoll pits with 3-inch ANSI mounting flanges. Cannot be used with Options G, H, K or L.
B	Adds 20-mesh screen between upper and lower halves of the unit (81557-20)	P	Adds 4-inch spool piece to convert inlet flange to mate with 6-inch 300 lb ASA raised face flange (47199). Resultant valve height is 16 inches (special order on 60554-2D & 3D).
C	Adds six-position product selection (44290)	Q	Changes upper half housing (adapter) to one-piece ductile iron (special order - not available on Model 60554-3D)
G	Adds spool piece to convert inlet flange to mate with 6-inch 300 lb ANSI flange to meet IP standard (44364) (special order on 60554-2D & 3D)	R	Changes upper half housing (adapter) to two-piece ductile iron/stainless steel (not available on Model 60554-3D — special order)
H	Adds 4-mesh stone guard to inlet. Available only with Option G above (43578).	S	Changes upper half housing (adapter) to 316 Stainless Steel (43214-4) (special order)
K	Adds adapter kit to D, E or F options only, to mate Avery Hardoll 12 inch pits. Cannot be used with option U.	T	Adds fusible plug to air port to either E, F, J or U options only (not available on Option X)
L	Adds adapter kit to D, E or F options only, to mate Avery Hardoll 13 inch pits. Cannot be used with Option U.	Y	Adds lanyard quick release bracket assembly with valve stem assembly
M	Adds dry break (with bleed) to Option E, F, J or U air connection (not available on Option X)	Z	Adds actuator assembly with override

Example: 60554BDGH — IP standard unit with 6-inch inlet, manually operated pilot valve, stone guard and 20-mesh screen

Superseding Data

Since the late 1960's, Eaton's Carter product line of hydrant valves have been manufactured in a number of different designs and models. Several of these models are no longer manufactured and spare part support has been discontinued. The list of hydrant valve model numbers (right) provides the superseding data to allow one to specify and procure the latest units of the series. Use this list to obtain the appropriate current model number (60554 or 61654) and then refer to the appropriate table of options for either Model 60554 or 61654 hydrant valves to complete the part number. (For Model 61654 options, see brochure TF100-86).

Model	Description	Superseded by - Comments
60550	4x4-inch API adapter with manual butterfly isolation valve at inlet	No longer supported with spare parts. Replace with appropriate Model 60554 hydrant valve.
60551	4x4-inch API outlet adapter with dual flapper, lanyard operated inlet valve	No longer supported with spare parts. Replace with appropriate Model 60554 hydrant valve.
60552	Same as Model 60551 except added interlock to close hydrant should coupler be inadvertently removed	No longer supported with spare parts. Replace with appropriate Model 60554 hydrant valve.
60553	4x4-inch API outlet adapter with air-operated inlet valve utilizing dual externally mounted cylinders	No longer supported with spare parts. Replace with appropriate Model 60554 hydrant valve.
60554-1	Air-operated Model 60554 type hydrant valve except 6x4-inch with outer housings and poppet material per ASTM A536-72, grade 80-55-06	Spare parts common to standard Model 60554. For new orders use Model 61654EK (part number change only).
60554 SPECIAL/ 60554-2D	Same as Model 60554 series except material for outer housings per ASTM A395	
60555	Aluminum inlet to mate 6-inch 300 lb flange x 4-inch API outlet, in accordance with IP standard	Spare parts support continues for all parts except inlet housing. Inlet housing can be replaced with a kit of current ductile iron parts.
61153	6x4-inch inlet mates 150 lb flange with API outlet adapter. Air-operated pilot with defueling capability and 10-mesh screen.	Spare parts support continues. For new orders use Model 61654AJ (part number change only).

Valve Operation

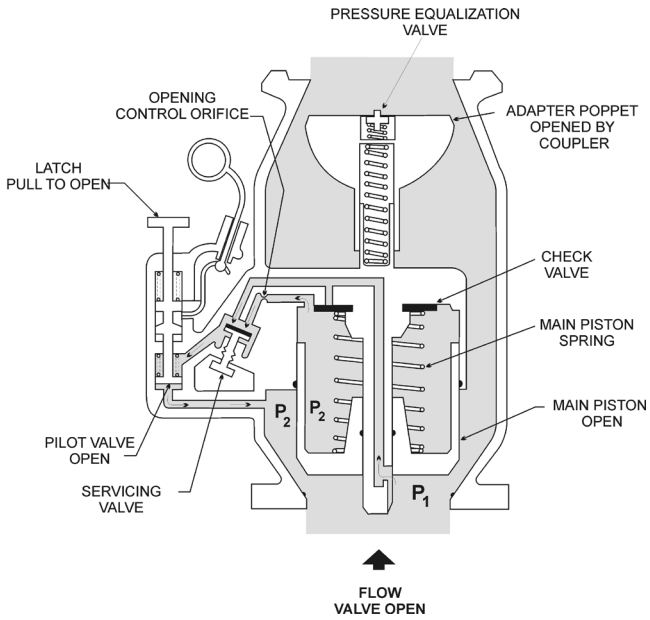

Figure A
Valve Open

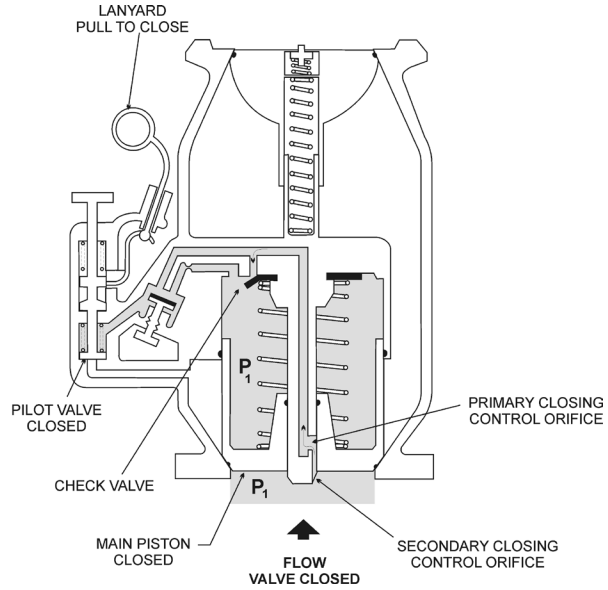

Figure B
Valve Closed

Figure A reflects a lanyard operated pilot valve shown in the open position. Figure B reflects an air-operated pilot in a closed position. The operation of the hydrant valve, whether the pilot is lanyard or air-operated, is identical. The only differences are in the operating mechanism that supplies the power to open and close the pilot valve. In the air-operated pilot, the closing lanyard and opening latching mechanisms are replaced with an air-operated piston as can be seen in the cutaway on the previous page. The dual air/lanyard operated pilot valve has the same normal air-operated pilot valve function with a manual (lanyard) over-ride of the air supply. (Option X works the same as that shown in figure B with the air/fuel-operated piston being placed on the hose from the servicer.)

Servicing Valve Closed/ Pilot Valve Open or Closed

The closing of the servicing valve has the same affect as closing the pilot valve. That is, the flow passage from the piston chamber to the downstream side of the piston is blocked. The piston chamber pressure begins to equalize to the inlet pressure (P1) through the check valve. The piston area is greater than

the effective seal area, hence the unbalance of forces caused by the equal pressure, plus the spring, will cause the valve to stay closed.

Pilot Valve Open/ Servicing Valve Open

The open pilot valve allows the continuous passageway from the main piston chamber and from the closing control orifice. The piston chamber is vented through an opening control orifice and the open servicing valve to a point in the lower valve half. The pressure (P2) at this point is less than the inlet pressure (P1). The piston chamber pressure is also maintained at P2 causing an unbalance of forces on the piston. The inlet pressure force is greater than the combined piston pressure force plus the spring force hence the valve will open to allow flow. This is assuming that the outlet adapter poppet in the upper valve half has been opened by a coupler.

The pilot poppet is maintained in the open position by one of two methods:

- Lanyard operated pilot — The pilot is opened by the pull of the "T" handle located on the top of the

pilot valve. When it is pulled upward, the spring loaded latch attached to the lanyard pivots to lock the pilot into the open position.

- Air-operated pilot/dual air-lanyard pilot — air pressure applied to the pilot piston will maintain the pilot in the open position until the pressure has been depleted (by release of deadman).

Pilot Valve Closed/ Servicing Valve Open

Pulling the lanyard, or depleting the air supplied to their respective pilots, will allow the spring loaded pilot poppet to close. This action blocks off the venting of the piston chamber to the lower pressure area downstream. The piston chamber begins to equalize to the inlet pressure (P1) through the check valve.

The piston area is greater than the effective seal area, hence the unbalance of forces caused by the equal pressure plus the spring will cause the piston to begin to close. As the piston moves toward the closed position, the piston chamber volume increases and must be filled through the two in series orifices. The primary orifice is

considerably larger than the secondary (slot). During the initial and majority of the travel of the piston, the primary orifice is fully exposed to the inlet pressure, hence the rate of closure is controlled by this orifice.

When the piston moves far enough closed to cover the primary orifice, the secondary (smaller) orifice begins to control the closure rate. Hence the valve begins to close relatively rapidly and then slows down as it nears its closed position. The relative size and locations of these two orifices allows the valve to close to provide a minimum of overshoot and yet limit the surge pressure shock, on closing, and still maintain a closure rate in accordance with applicable international specifications.

On Model 60554J with defueling option, the pilot valve is manually held closed by the thumb screw to allow defueling flow.

The dual pilot valve options F or U perform under normal situations the same as option E. The lanyard operation is only for emergency situations where the air supply is not released by the deadman valve.

Technical Data

Flow Characteristics

The graphs on this page depict typical pressure drop versus flow characteristics of the 60554 series hydrant pit valves. (Option X does not alter the pressure drop characteristics of the 60554).

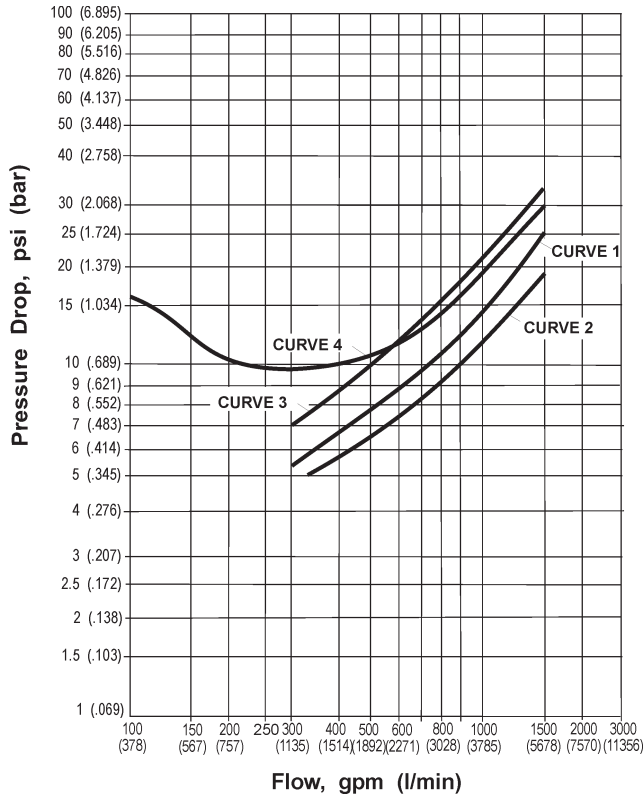

- Curve 1** Model 60554BDGH (IP hydrant) or 60554BFGH, 20-mesh screen and 61525 Coupler
- Curve 2** Model 60554BD, (BE), (BU), 20-mesh screen and 61525 Coupler
- Curve 3** Model 60554BJ, 20-mesh screen and 61525, fueling direction
- Curve 4** Model 60554BJ, 20-mesh screen and 61525 Coupler, defueling direction

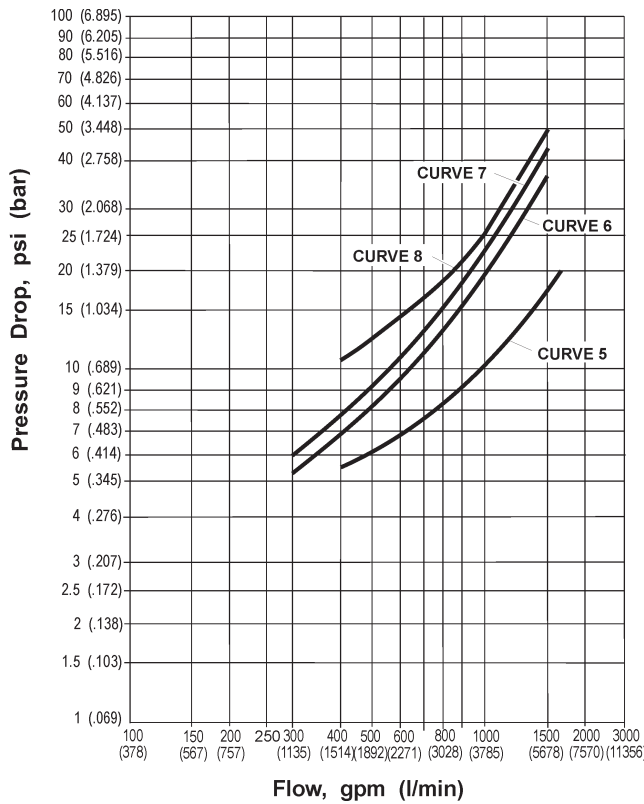

- Curve 5** Model 60554D, (E), (U), no screen and Model 61525 Coupler
- Curve 6** Model 60554E (D), (U), no screen and Model 60600H Coupler
- Curve 7** Model 60554E (D), (F), no screen and Model 60700K Coupler
- Curve 8** Model 60554E (D), (U), no screen and Model 60600K Coupler

Eaton
Aerospace Group
Fluid & Electrical Distribution Division
9650 Jeronimo Road
Irvine, California 92618
Phone: (949) 452 9500
Fax: (949) 452 9992
E-mail: groundfueling@eaton.com